

ITT

Wastewater

Goulds Pumps

3887ZBF Submersible Sewage Pump



FEATURES

- **Impeller:** Cast iron, semi-open, non-clog, dynamically balanced with pump out vanes for mechanical seal protection. Optional silicon bronze impeller available.
- **Casing:** Cast iron flanged volute type for maximum efficiency. Designed for easy installation on A10-20 slide rail.
- **Mechanical Seals: SILICON CARBIDE VS. SILICON CARBIDE** sealing faces for superior abrasive resistance, stainless steel metal parts, BUNA-N elastomers.
- **Shaft:** Corrosion resistant, 400 series stainless steel. Threaded design. Locknut on three phase models to guard against component damage on accidental reverse rotation.
- **Fasteners:** 300 series stainless steel.
- Capable of running dry without damage to components.
- Designed for continuous operation, when fully submerged.



Goulds Pumps is a brand of ITT Corporation.

www.goulds.com

Engineered for life

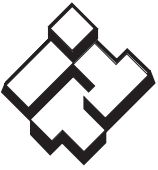

ITT

GOULDS PUMPS Wastewater

APPLICATIONS

Specifically designed for the following uses:

- Homes
- Sewage systems
- Dewatering/Effluent
- Water transfer
- Light industrial
- Commercial applications

Anywhere waste or drainage must be disposed of quickly, quietly and efficiently.

SPECIFICATIONS

Pump

- Solids handling capabilities: 2" maximum.
- Capacities: up to 160 GPM.
- Total heads: up to 26 feet TDH.
- Discharge size: 2" NPT threaded companion flange standard. 3" option available but must be ordered separately. (Order no. A1-3)
- 2" or 3" BSPP Connection (optional).
- Temperature:
104°F (40°C) continuous
140°F (60°C) intermittent.
- See order numbers on reverse side for specific HP, voltage, phase and RPMs available.

MOTORS

■ Fully submerged in high grade turbine oil for lubrication and efficient heat transfer. All ratings are within the working limits of the motor.

■ Class B insulation.

- All single phase models feature capacitor start motors for maximum starting torque.

Single phase (50 Hz):

- Built-in overload with automatic reset.
- 1/3 and 1/2 HP – 16/3 SJTOW with bare leads.
- 3/4 – 14/3 STOW with bare leads.

Three phase (50 Hz):

- Overload protection must be provided in starter unit.
- 1 1/3 - 3/4 HP – 14/4 STOW with bare leads.

■ **Designed for Continuous Operation:** Pump ratings are within the motor manufacturer's recommended working limits, can be operated continuously without damage.

■ **Bearings:** Upper and lower heavy duty ball bearing construction.

■ **Power Cables:** Severe duty rated, oil and water resistant. Epoxy seal on motor end provides secondary moisture barrier in case of outer jacket damage and to prevent oil wicking. 20 foot standard with optional lengths available.

■ **Motor Cover O-ring:** Assures positive sealing against contaminant and oil leakage.

Goulds Pumps is ISO 9001 Registered.

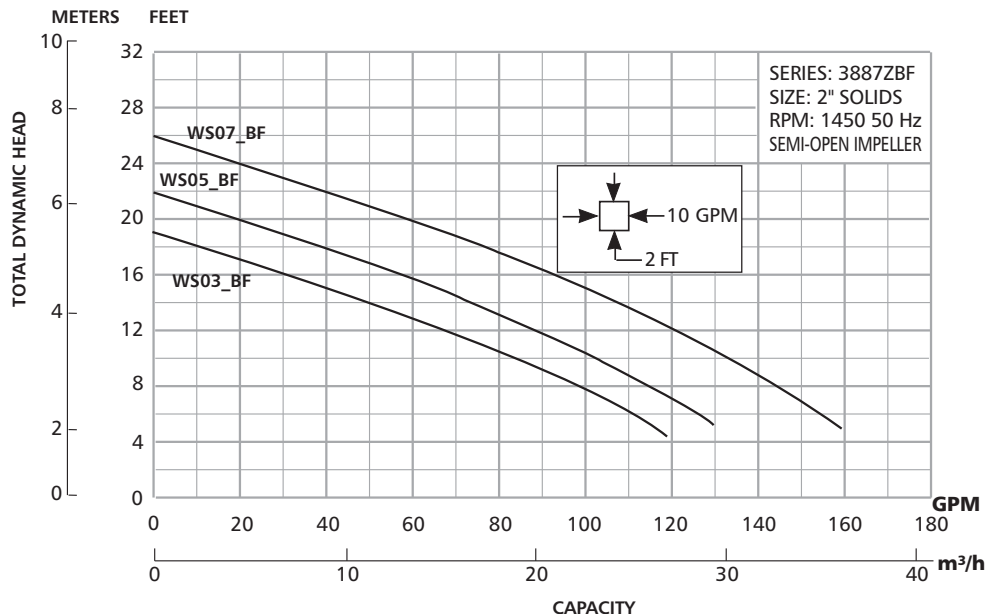

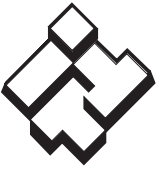

ITT

GOULDS PUMPS Wastewater

COMPONENTS FOR REFERENCE ONLY

Item No.	Description
1	Impeller
2	Casing
3	Silicon carbide vs. silicon carbide Mechanical seal
4	Shaft
5	Motor
6	Ball bearings
7	Power cable
8	O-ring

NOTE: Repair parts may be ordered from repair parts list.

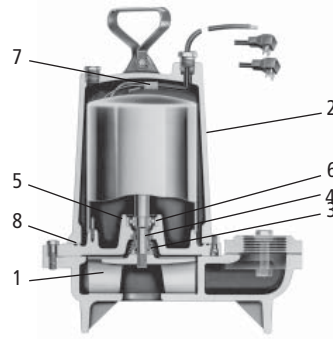

DIMENSIONS

(All dimensions are in inches. Do not use for construction purposes.)

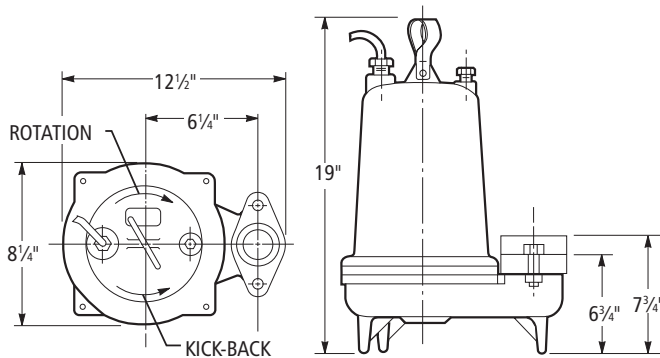

MODELS

Order No.	HP	Volts	Phase	RPM	Impeller Diameter	Max. Amps	Wt. (lbs.)
WS0321BF	1/3	115	1	1450	5"	15	68
WS0329BF		220	1			7.2	68
WS0346BF		380	3			1.3	68
WS0521BF	1/2	115	1		5 3/8"	15	70
WS0529BF		220	1			7.8	70
WS0546BF		380	3			1.5	70
WS0729BF	3/4	220	1		5 3/4"	8.6	75
WS0746BF		380	3			2.3	75

Complete System Components available in the accessory section of this catalog.



ITT

Wastewater



Goulds Pumps and the ITT Engineered Blocks Symbol are registered trademarks and tradenames of ITT Corporation.

SPECIFICATIONS ARE SUBJECT TO CHANGE WITHOUT NOTICE.

B3887ZBF May, 2007

© 2007 ITT Corporation.

Engineered for life