

ITT

Wastewater

Goulds Pumps

PV Submersible Vortex
Sewage Pump



FEATURES

- Corrosion resistant construction.
- Cast iron body.
- Thermoplastic impeller and cover.
- Upper sleeve and lower heavy duty ball bearing construction.
- Motor is permanently lubricated for extended service life.
- Powered for continuous operation.
- Vortex impeller is recessed to allow free flow through casing.
- All ratings are within the working limits of the motor.
- Replaceable power cord, 10' and 20' standard lengths, heavy duty 16/3 SJTW with NEMA three prong, 115 or 230 volt grounding plug.
- Complete unit is heavy duty, portable and compact.
- Mechanical seal is carbon, ceramic, BUNA and stainless steel.
- Stainless steel fasteners.

 **GOULDS PUMPS**

Goulds Pumps is a brand of ITT Water Technology, Inc.
- a subsidiary of ITT Industries, Inc.

www.goulds.com

Engineered for life

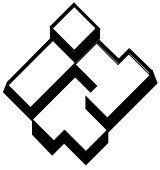

ITT

GOULDS PUMPS Wastewater

APPLICATIONS

Specially designed for the following uses:

- Residential sewage systems
- Heavy duty sump/dewatering
- Water transfer

SPECIFICATIONS

Pump

- Discharge: 2" NPT
- Maximum capacity: 100 GPM
- Maximum head: 22' TDH
- Vortex Impeller
- Solids handling: 2" maximum sphere.
- Temperature: 104°F (40°C) maximum, continuous when fully submerged.
- Automatic models include a float switch.
- Manual models available.
- Pumping range: see performance chart or curve.

MOTOR

- Single phase
- 60 Hertz
- 115 and 230 volt
- Built-in thermal overload protection with automatic reset.
- Class B insulation.
- Oil-filled design.
- High strength carbon steel shaft.

PV5 Motor:

- .50 HP, 3400 RPM
- PSC design

AGENCY LISTINGS



Tested to UL 778 and
CSA 22.2 108 Standards
By Canadian Standards Association
File #LR38549

Goulds Pumps is ISO 9001 Registered.

MODEL INFORMATION

Order No.	HP	Volts	Amps	Minimum Circuit Breaker	Phase	RPM	Float Switch Style	Power Cord Length	Discharge Connection	Maximum Solids Size	Minimum Basin Diameter	Shipping Weight lbs/kg
PV51M	½	115	13.0	20	1	3450	Plug / No Switch	10'	2"	2"	18"	40
PV51P1							Piggyback Wide Angle	10'				42
PV51MF							Plug / No Switch	20'				42
PV52MF		230	6.5	15			Plug / No Switch	20'				42
PV51P1F		115	13.0	20			Piggyback Wide Angle	20'				44
PV52P1F		230	6.5	15			Piggyback Wide Angle	20				44

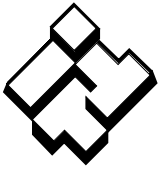

ITT

GOULDS PUMPS Wastewater

PERFORMANCE CHARTS

These charts show actual system performance with friction loss factored in for various discharge pipe lengths. Calculations and performance based on a system with 2" PVC, schedule 40 plastic pipe (C150), (4) 90° elbows, (1) check valve and (1) shut-off valve. Wastewater requires a minimum scouring velocity of 21gpm for 2" pipe. Shaded areas do not provide min. scouring velocity - use only for gray water with no solids.

Pipe Length (Feet)	GPM									
	Vertical Head (Feet)									
	2	4	6	8	10	12	14	16	18	20
25	95	89	83	77	70	62	53	45	35	22
50	83	78	73	67	61	55	48	40	31	20
75	76	71	66	61	55	50	43	37	28	18
100	69	65	61	56	51	46	40	33	26	17
150	60	57	53	49	45	40	35	29	23	16
200	54	51	48	44	40	36	32	27	21	14
250	49	47	44	40	37	33	29	24	19	13
300	46	43	40	37	34	31	27	23	18	12

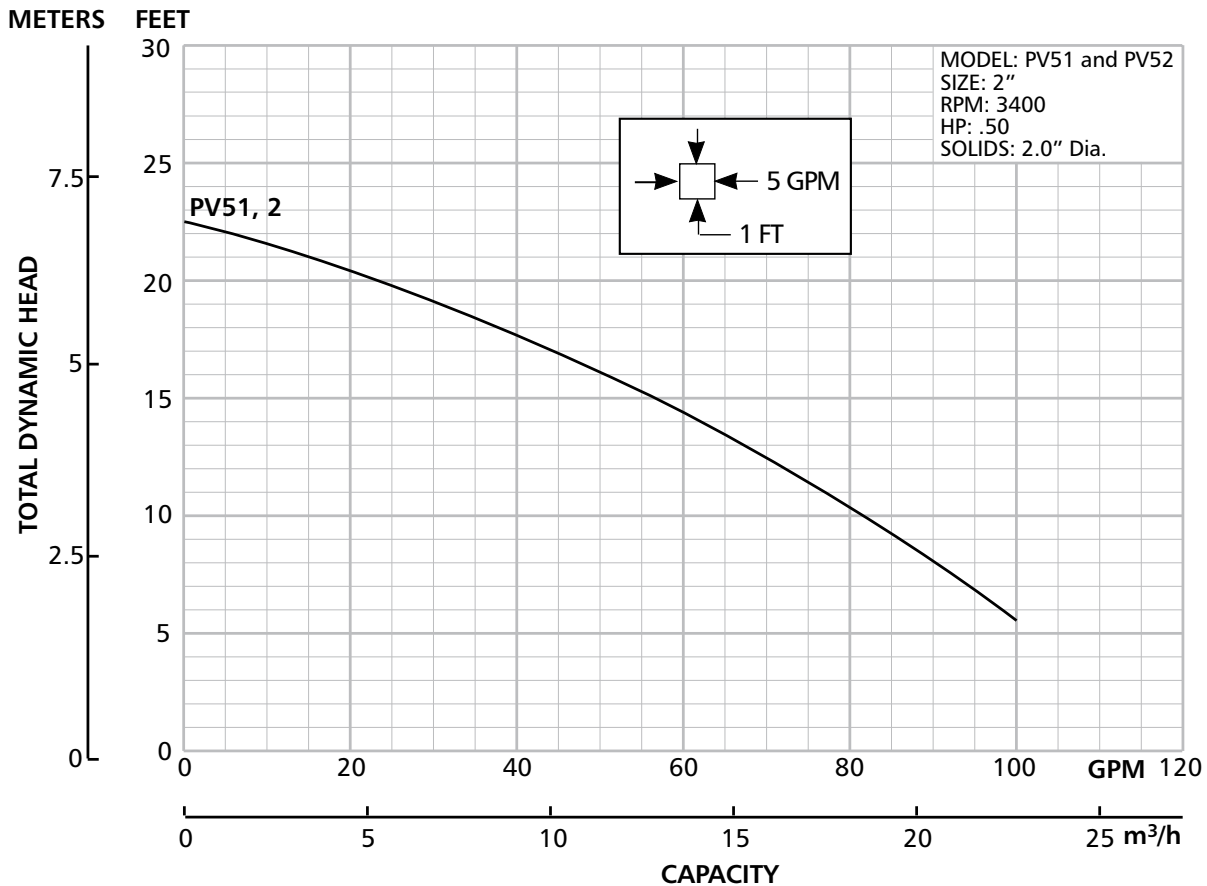

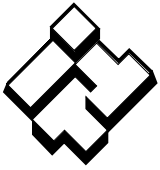

ITT

Wastewater

DIMENSIONS

(All dimensions are in inches. Do not use for construction purposes.)

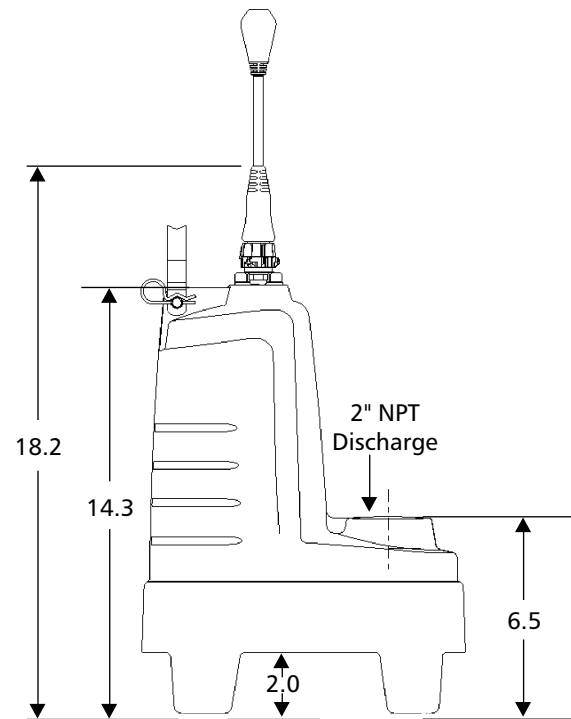
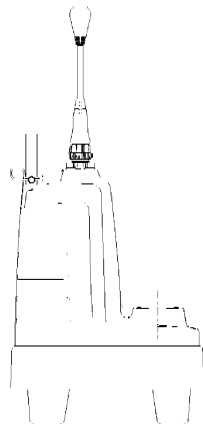
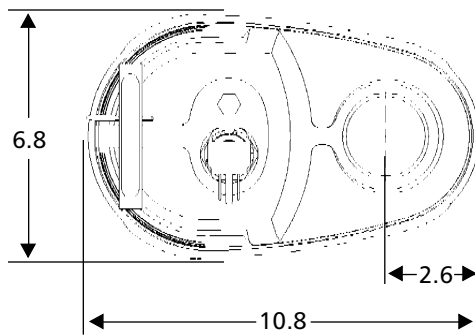

Goulds Pumps and the ITT Engineered Blocks Symbol are registered trademarks and tradenames of ITT Industries Inc.

SPECIFICATIONS ARE SUBJECT TO CHANGE WITHOUT NOTICE.

BPV March, 2006

© 2006 ITT Water Technology, Inc.

Engineered for life