



ITT

Commercial Water

Goulds Pumps

CentriBoost™

Fixed Speed Pumping Package

Installation, Operation and Maintenance Instructions

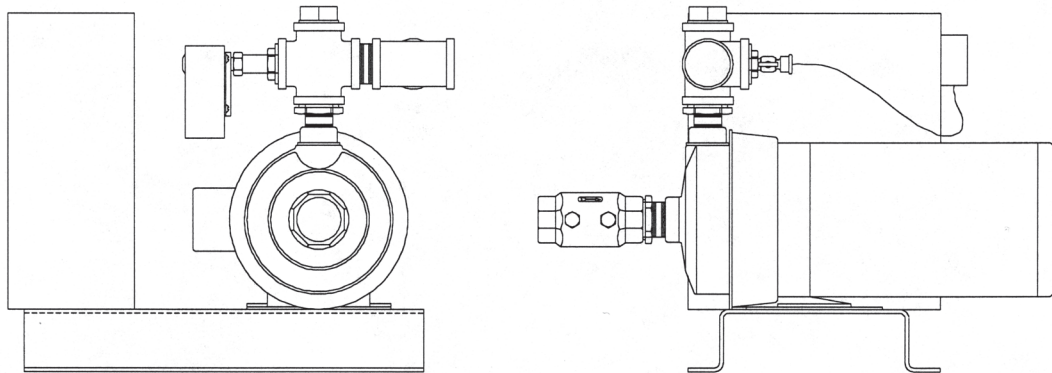

Single or dual pump pressure booster for boosting system pressure by as much as 55 PSI. The pump is automatically controlled to run on demand to save energy.



Goulds Pumps is a brand of ITT
Residential and Commercial Water.

www.goulds.com

Engineered for life

Table of Contents

SECTION 1	- Safety Instructions	3
	- General Description	3
	- Purpose of Manual.	3
	- Storage and Handling	3
	- Electrical Connections	3
SECTION 2	- Installation	4
SECTION 3	- Putting the Unit into Service	5
	- Adjustments and Settings	5
SECTION 4	Final Check Lists	
	- Start Up Check List - Piping	6
	- Start Up Check List - Electrical	6
SECTION 5	Troubleshooting	6-7
APPENDIX 1	Programmable Pump Sequence Control Module for Duplex Units	8
FIELD PIPING	9
LIMITED WARRANTY	12

NOTE: The information contained in this manual is intended to assist operating personnel by providing information on the characteristics of the purchased equipment.

It does not relieve the user of the responsibility to adhere to local codes and ordinances and the use of accepted practices in the installation, operation and maintenance of this equipment.

Further information pertaining to the installation, operation and maintenance of your CentriBoost Pumping System can be found in the Installation, Operation and Maintenance manuals for the associated equipment provided:

- A. Goulds Pumps Model NPE
- B. Tank (Model Specific)

Owner's Information

Pump Model Number: _____

Pump Serial Number: _____

Control Model Number: _____

Dealer: _____

Dealer Phone No. _____

Date of Purchase: _____ Installation: _____

Current Readings at Startup:

1Ø

Amps: _____

Volts: _____

SECTION 1

SAFETY INSTRUCTIONS

TO AVOID SERIOUS OR FATAL PERSONAL INJURY OR MAJOR PROPERTY DAMAGE, READ AND FOLLOW ALL SAFETY INSTRUCTIONS IN MANUAL AND ON PUMP.

THIS MANUAL IS INTENDED TO ASSIST IN THE INSTALLATION AND OPERATION OF THIS UNIT AND MUST BE KEPT WITH THE PUMP.



This is a **SAFETY ALERT SYMBOL**. When you see this symbol on the pump or in the manual, look for one of the following signal words and be alert to the potential for personal injury or property damage.



⚠ DANGER

Warns of hazards that **WILL** cause serious personal injury, death or major property damage.



⚠ WARNING

Warns of hazards that **CAN** cause serious personal injury, death or major property damage.



⚠ CAUTION

Warns of hazards that **CAN** cause personal injury or property damage.

NOTICE: INDICATES SPECIAL INSTRUCTIONS WHICH ARE VERY IMPORTANT AND MUST BE FOLLOWED.

THOROUGHLY REVIEW ALL INSTRUCTIONS AND WARNINGS PRIOR TO PERFORMING ANY WORK ON THIS PUMP.

MAINTAIN ALL SAFETY DECALS.

GENERAL DESCRIPTION

The CentriBoost pumping package is a fixed constant speed, and will increase the domestic water pressure at the fixtures from 20 to 55 PSI above that of the city water pressure.

Depending upon the pumping capacity required, a Simplex (one pump) type or a Duplex (two pump) type is used. In both types, a pressure switch starts and stops the pump(s).

PURPOSE OF MANUAL

This manual is furnished to acquaint you with some of the practical ways to install, operate and maintain this unit. Read it completely before doing any work on your unit and keep it handy for future reference.

Equipment cannot operate well without proper care. To keep this unit at top efficiency, follow the recommended installation and servicing procedure outlined in this manual.

ADDITIONAL SAFETY REQUIREMENTS



⚠ WARNING

ELECTRICAL SHOCK HAZARD. INSPECT ALL ELECTRICAL CONNECTIONS PRIOR TO POWERING THE UNIT. WIRING CONNECTIONS MUST BE MADE BY A QUALIFIED ELECTRICIAN IN ACCORDANCE WITH ALL APPLICABLE CODES, ORDINANCES AND GOOD PRACTICES.

FAILURE TO FOLLOW THESE INSTRUCTIONS COULD RESULT IN SERIOUS PERSONAL INJURY, DEATH, AND/OR PROPERTY DAMAGE.



⚠ WARNING

PREVENT ELECTRICAL SHOCKS. DISCONNECT THE POWER SUPPLY BEFORE BEGINNING INSTALLATION. FAILURE TO FOLLOW THESE INSTRUCTIONS COULD RESULT IN SERIOUS PERSONAL INJURY, DEATH AND/OR PROPERTY DAMAGE.

Always use accurate test meters when checking electrical components. Always work with another person in case of emergency.

STORAGE

For long periods of storage, the unit should be covered to prevent corrosion and contamination from dirt. It should be STORED in a clean, dry location between 0 and 170° F. The relative humidity should not exceed 85%. The unit should be checked periodically to ensure that no condensation has formed. After storage, again check that it is dry before applying power.

HANDLING

Care should be taken to prevent damage due to dropping or jolting when moving the CentriBoost. Transportation damage should be brought to the carrier's attention immediately upon receipt.

TEMPERATURE AND VENTILATION

All electrical equipment is susceptible to failure if operated in ambient temperatures outside of its rating. The OPERATING temperature range for this unit is 32 to 105° F. The relative humidity should not exceed 95% non-condensing. The unit should not be operated outside these extremes.

ELECTRICAL CONNECTIONS - A.C. POWER AND SIGNALS INPUT VOLTAGE

The input voltage tolerance is +10/-10% of nameplate voltage.

GROUND CONNECTIONS

A grounding terminal is provided for a dedicated ground wire connection. All provisions of the National Electrical Code and local codes must be followed.



⚠ WARNING

CONDUIT GROUNDS ARE NOT ADEQUATE. A SEPARATE GROUND WIRE MUST BE ATTACHED TO THE GROUND LUG PROVIDED IN THE ENCLOSURE TO AVOID POTENTIAL SAFETY HAZARDS. FAILURE TO FOLLOW THESE INSTRUCTIONS COULD RESULT IN SERIOUS PERSONAL INJURY, DEATH AND/OR PROPERTY DAMAGE.

POWER WIRING

Power wire types and sizes must be selected based upon conformance with the National Electrical Code and all local codes and restrictions. In addition, only copper

(Cu) wire rated for at least 75° C may be used for the power connections. Refer to the input current as listed on the motor nameplate when sizing wire.

FIELD CONNECTION DIAGRAMS

Refer to the NPE pump Installation, Operation and Maintenance manual for specific details unique to the pump.

The following field connection diagrams should be reviewed prior to unit installation and operation.

<u>Drawing #</u>	<u>Description</u>	<u>Page</u>
1MBD02	Piping: Simplex	8
1MBD03	Piping: Duplex	9
1SWD01 or 1SWD02	Wiring, Simplex (shipped with unit)	
1SWD03	Wiring, Duplex (shipped with unit)	
1380 _ _	Unit specific Drawing (shipped with unit)	

SECTION 2

INSTALLATION INSTRUCTIONS

Locate the pumping unit for ease of inspection, maintenance, and service.

Place the unit preferably on a concrete floor or base. Level the steel base, on which the pumps are mounted, in both directions by placing steel shims between the base and the anchor bolts.

⚠ DANGER HEAVY LOAD, MAY DROP IF NOT LIFTED PROPERLY. DO NOT LIFT THE ENTIRE UNIT BY THE MOTOR EYEBOLTS. LIFT THE UNIT WITH SLINGS PLACED UNDER THE UNIT BASE RAILS. FAILURE TO FOLLOW THESE INSTRUCTIONS COULD RESULT IN SERIOUS PERSONAL INJURY, DEATH AND/OR PROPERTY DAMAGE.

A well-leveled and secured unit will result in quiet operation as well as longevity of service.

See drawing 1MBD02 (Simplex) or 1MBD03 (Duplex) in Section 6 for general piping requirements.

Eccentric increasers can be used in the suction line when increasing the pipe size. The straight side of eccentric reducers should be installed with the flat side on top to eliminate air pockets. Support the suction and discharge lines independently by the use of pipe hangers or anchors. Do not attempt to spring the suction and discharge lines into position. It is recommended that a three (3) valve by-pass between the suction and discharge be installed at this time. See drawing 1MBD02 or 1MBD03 for location of valves.

IMPORTANT: Do not install and operate Goulds pumps in closed systems unless the system is constructed with properly sized safety devices and control devices. Such devices include the use of properly sized and located pressure relief valves, compression tanks, pressure controls, temperature controls and flow controls as appropriate. The CentriBoost includes a high temperatures

cut out. If the system does not include the other devices, consult the responsible engineer or architect before making pumps operational.

⚠ WARNING THE HEATING OF WATER AND OTHER FLUIDS CAUSES VOLUMETRIC EXPANSION. THE ASSOCIATED FORCES MAY CAUSE FAILURE OF SYSTEM COMPONENTS AND RELEASE OF HIGH TEMPERATURE FLUIDS. THIS WILL BE PREVENTED BY INSTALLING PROPERLY SIZED AND LOCATED PRESSURE RELIEF VALVES AND COMPRESSION TANKS. FAILURE TO FOLLOW THESE INSTRUCTIONS COULD RESULT IN SERIOUS PERSONAL INJURY, DEATH AND/OR PROPERTY DAMAGE.

IMPORTANT: Unless the piping to which the vibration eliminators are connected to are properly anchored to the floor, the benefits may not be fully realized. See drawing 1MBD02 (Simplex) or 1MBD03 (Duplex).

⚠ WARNING ELECTRICAL SHOCK HAZARD. INSPECT ALL ELECTRICAL CONNECTIONS PRIOR TO POWERING THE UNIT. WIRING CONNECTIONS MUST BE MADE BY A QUALIFIED ELECTRICIAN IN ACCORDANCE WITH ALL APPLICABLE CODES, ORDINANCES, AND GOOD PRACTICES. FAILURE TO FOLLOW THESE INSTRUCTIONS COULD RESULT IN SERIOUS PERSONAL INJURY, DEATH, AND/OR PROPERTY DAMAGE.

The power supply required for the unit is either 230/1/60 or 208, 230, 460/3/60 with a dedicated ground wire. Single phase motors have internal overload protection and three phase motors have external overload protection in the control panel.

On single phase units the disconnecting means and short circuit protection are to be supplied and mounted by others. Three phase units have disconnecting means and fuses for short circuit protection in the control panel.

For units installed with an optional tank, the tank must be installed to the top connection of the discharge cross for simplex units and the discharge manifold for duplex units (see 1MBD02 or 1MBD03). Precharge the tank per the tank specific IOM.

For units installed with an optional low suction pressure switch, the switch, which typically ships loose, must be piped to the inlet 1/4" tap on the check valve for simplex units or on of the 1/4" tap on the suction manifold for duplex units (see 1MBD02 or 1MBD03). See section 3.10 for instructions on setting the switch.

⚠ WARNING CONDUIT GROUNDS ARE NOT ADEQUATE. A SEPARATE GROUND WIRE MUST BE ATTACHED TO THE GROUND LUG PROVIDED IN THE ENCLOSURE TO AVOID POTENTIAL SAFETY HAZARDS. FAILURE TO FOLLOW THESE INSTRUCTIONS COULD RESULT IN SERIOUS PERSONAL INJURY, DEATH AND/OR PROPERTY DAMAGE.

⚠ CAUTION SEAL DAMAGE MAY OCCUR. DO NOT RUN PUMPS DRY. FILL AND VENT THE PUMP VOLUTE PRIOR TO OPERATION. FAILURE TO FOLLOW THESE INSTRUCTIONS COULD RESULT IN PROPERTY DAMAGE AND/OR MODERATE PERSONAL INJURY.

SECTION 3

PUTTING THE UNIT INTO SERVICE

⚠ CAUTION PREVENT SUBSEQUENT DAMAGE. A UNIT SHOWING SYMPTOMS OF POSSIBLE PROBLEMS (NOISE, LEAKS, VIBRATION, AND/OR CONTINUAL OPERATION) MUST BE CORRECTED IMMEDIATELY. FAILURE TO FOLLOW THESE INSTRUCTIONS COULD RESULT IN PROPERTY DAMAGE AND/OR MODERATE PERSONAL INJURY.

Simplex package - for capacities up to 110 GPM.

Whenever the city water pressure falls below the system pressure switch setting the pump will start through a power relay.

When the system pressure rises above the setting of the system pressure switch the pump will stop (provided the minimum run timer has expired.)

Duplex package - for capacities up to 220 GPM.

The lead pump operates identically to the Simplex package. However, if the draw rate continues to increase beyond the capacity of the lead pump, the system pressure will fall and cause Pump 2 On/Off pressure switch to trip which in turn starts the lag pump.

Both pumps will continue to run until the system pressure rises above the setting of Pump 1 and Pump 2 pressure switches (provided the minimum run timers have expired.)

For the duplex unit Pump 2 also acts as a Standby for Pump 1. In the event there is a call for Pump 1 and it has failed for whatever reason, Pump 2 will start and act as the lead pump. Once Pump 1 is fixed, place the Pump 1 HOA into the Off/Reset position and then back to Auto to reset the unit.

Simplex and Duplex units will run when there is demand unless one of the following conditions occurs:

- 1) The optional low suction pressure switch trips due to low city pressure
- 2) The high temperature cut out switch trips due to the pump deadheading.

The low suction condition will reset automatically when city pressure returns to an acceptable level.

If the unit cuts out on high temperature the unit can reset automatically when there is demand by drawing cooler water throughout the unit and across the temperature sensor. This will cool the sensor and cause it to change state and restart the pump. A manual purge can be done by running the unit in "Hand" for about 5 seconds. The unit can then be put back into "Auto" for normal operation.

ADJUSTMENTS AND SETTINGS

Low Suction Pressure Switch (Optional)

⚠ WARNING ELECTRICAL SHOCK HAZARD. SINGLE PHASE OR THREE PHASE AC POWER. DISCONNECT AND LOCKOUT POWER BEFORE SERVICING THE UNIT. FAILURE TO FOLLOW THESE INSTRUCTIONS COULD RESULT IN

SERIOUS PERSONAL INJURY, DEATH AND/OR PROPERTY DAMAGE.

The pressure switch is piped into the suction line. There is an adjusting dial located inside of the control. This adjustment controls the low suction cutout.

The differential pressure setting is fixed at 1.5 PSI. Therefore cut in pressure will be the switch setting plus 1.5 PSI.

Although the scale is calibrated in PSI, it may not correspond exactly to the actual suction gage indication. Therefore, for critical installations, the setting should be adjusted according to the gage reading.

The approximate settings should be set prior to placing the unit in operation to suit the pressure conditions at the installation.

System Pressure Switch (Simplex), Pump 1 and Pump 2 Pressure Switch for Duplex

⚠ WARNING ELECTRICAL SHOCK HAZARD. DISCONNECT AND LOCKOUT POWER BEFORE SERVICING THE UNIT. FAILURE TO FOLLOW THESE INSTRUCTIONS COULD RESULT IN SERIOUS PERSONAL INJURY, DEATH AND/OR PROPERTY DAMAGE.

This switch is piped to the discharge header piping. There are two adjusting screws located on the top of the control. Facing the switch, the screw on the right hand side sets the cut-out point. This adjustment must be made first.

The screw to the left and towards the front sets the cut-in point. Turn the screw until the proper cut-in point is obtained.

Although the scales are calibrated in PSI, they may not correspond exactly to the actual discharge gage indication. Therefore, for critical installations, the settings should be adjusted according to the gage reading. See wiring diagram 1SWD04 for proper settings of the system pressure switches on a duplex unit.

Minimum Run Timer

For a simplex unit the minimum run timer is factory set to 5 minutes. The setting should be verified before unit is placed into operation and adjusted if a shorter minimum run time is desired. See Appendix 1 for instructions on using the programmable pump sequence control module to set the minimum run timers for a duplex unit. Appendix 1 also contains information about setting additional parameters that are specific to duplex units.

Aquastat

The aquastat for high temperature cut out is factory set for 100° F and should be adjusted if a different cut out temperature is desired. The switch should not be set above 225° F.

Optional Tank

Since a variety of different tanks can be used with either the simplex or duplex units refer to the specific IOM that was shipped with the tank for installation and operating instructions.

SECTION 4

INSTALLATION INSTRUCTIONS

A. SYSTEM PIPING AND UNIT INSTALLATION

- _____ 1. Is the unit base properly leveled and secured?
- _____ 2. Are all lubrication points properly lubricated?
- _____ 3. Is the shut-off valve to the pump suction open?
- _____ 4. Is the shut-off valve on the discharge line open?
- _____ 5. Is the bypass valve, if used, closed?
- _____ 6. Is the piping properly supported to prevent strains on unit?
- _____ 7. Is the system, including the pumps, purged of debris and air?

CAUTION SEAL DAMAGE MAY OCCUR. DO NOT RUN PUMPS DRY. FILL AND VENT THE PUMP VOLUTE PRIOR TO OPERATION. FAILURE TO FOLLOW THESE INSTRUCTIONS COULD RESULT IN PROPERTY DAMAGE AND/OR MODERATE PERSONAL INJURY.

B. ELECTRICAL WIRING AND CONTROL SETTINGS

- _____ 1. Does the feeder line voltage correspond to the unit voltage? Check the unit nameplate or motor terminal connection.

WARNING ELECTRICAL SHOCK HAZARD. INSPECT ALL ELECTRICAL CONNECTIONS PRIOR TO POWERING THE UNIT. WIRING CONNECTIONS MUST BE MADE BY A QUALIFIED ELECTRICIAN IN ACCORDANCE WITH ALL APPLICABLE CODES, ORDINANCES, AND GOOD PRACTICES. FAILURE TO FOLLOW THESE INSTRUCTIONS COULD RESULT IN SERIOUS PERSONAL INJURY, DEATH AND/OR PROPERTY DAMAGE.

- _____ 2. Are the feeder wires correctly sized for the load?

WARNING CONDUIT GROUNDS ARE NOT ADEQUATE. A SEPARATE GROUND WIRE MUST BE ATTACHED TO THE GROUND LUG PROVIDED IN THE ENCLOSURE TO AVOID POTENTIAL SAFETY HAZARDS. FAILURE TO FOLLOW THESE INSTRUCTIONS COULD RESULT IN SERIOUS PERSONAL INJURY, DEATH AND/OR PROPERTY DAMAGE.

- _____ 3. Have all the power terminals in the control panel been checked for tightness? This is imperative since stranded wires tend to "flow" and become loose after initial installation.

WARNING ELECTRICAL SHOCK HAZARD. SINGLE PHASE OR THREE PHASE AC POWER. DISCONNECT AND LOCKOUT POWER BEFORE SERVICING THE UNIT. FAILURE TO FOLLOW THESE INSTRUCTIONS COULD RESULT IN SERIOUS PERSONAL INJURY, DEATH AND/OR PROPERTY DAMAGE.

- _____ 4. Are the pressure controls correctly set? The pressure switch(es) need to be set for proper operation. Any subsequent change in system operating conditions may require resetting the controls. For best results, use compressed air and a continuity meter (across the switch) to reset the controls. The legend plate on the control indicates approximate readings only, therefore, should be used with caution.

SECTION 5

TROUBLESHOOTING

DANGER TROUBLESHOOTING LIVE CONTROL PANELS EXPOSES PERSONNEL TO HAZARDOUS VOLTAGES. ELECTRICAL TROUBLESHOOTING MUST ONLY BE DONE BY A QUALIFIED ELECTRICIAN. FAILURE TO FOLLOW THESE INSTRUCTIONS WILL RESULT IN SERIOUS PERSONAL INJURY, DEATH AND/OR PROPERTY DAMAGE.

PUMP WILL NOT OPERATE:

- 1) Check incoming power
- 2) Check power fuses. Replace if blown.
- 3) Check transformer fuses. Replace if blown.
- 4) Check to see that control voltage is 120 volt.
- 5) Check motor overload. Reset if tripped.
- 6) Momentarily turn HOA switch to HAND position and back to OFF. Does starter pull in? If starter doesn't pull into go to next step. If it does pull in go to step 10.
- 7) Turn HOA switch to HAND position. Check voltage across terminals for coil in starter. If voltage is present and the starter is not pulled in, the coil is defective and must be replaced. If voltage isn't present go to step 8.
- 8) With HOA still in HAND, check voltage between HOT side of starter coil and the neutral (white) wire. 120 volts should be measured. If voltage is measured go to step 9.
- 9) With HOA still in HAND, check voltage between the hot side of coil & neutral (white wire) for over load block. 120 volts should be measured. If voltage is measured replace the overload block. If no voltage is present contact your local Goulds Pumps representative to service control circuit.

- 10) With starter pulled in, check voltage at bottom of overload block. Voltage should be the same as the incoming power. If no voltage is present, replace the starter. If voltage is present, contact electrician to check the leads and motor.

PUMP WILL NOT BUILD PRESSURE:

- 1) Check rotation; rotation should be as indicated on the pump volute. If rotation is wrong disconnect power. For three phase motors, switch any two leads at bottom of starter. If motor is single phase, refer to wiring diagram on nameplate.

⚠ DANGER HIGH VOLTAGE 3 PHASE POWER CAN KILL. DISCONNECT AND LOCK-OUT POWER PRIOR TO SERVICING UNIT. FAILURE TO FOLLOW THESE INSTRUCTIONS WILL RESULT IN SERIOUS PERSONAL INJURY, DEATH AND/OR PROPERTY DAMAGE.

- 2) Suction valve is closed. If closed, open.
- 3) Motor not operating at rated RPM. Have motor checked at local motor repair shop.
- 4) Internal pump damage. Take pump to authorized pump repair facility.

PUMP WILL NOT START AUTOMATICALLY:

⚠ WARNING ELECTRICAL SHOCK HAZARD. INSPECT ALL ELECTRICAL CONNECTIONS PRIOR TO POWERING THE UNIT. WIRING CONNECTIONS MUST BE MADE BY A QUALIFIED ELECTRICIAN IN ACCORDANCE WITH ALL APPLICABLE CODES, ORDINANCES AND GOOD PRACTICES. FAILURE TO FOLLOW THESE INSTRUCTIONS COULD RESULT IN SERIOUS PERSONAL INJURY, DEATH AND/OR PROPERTY DAMAGE.

- 1) No power. Restore if there is no power.
- 2) No control circuit. Restore control circuit power.
- 3) HOA switch not in the AUTO position. Turn switch to AUTO position.
- 4) System pressure (Simplex) or Pump 1 and Pump 2 (Duplex) pressure switches not adjusted properly. Refer to section 3.

APPENDIX 1

PROGRAMMABLE PUMP SEQUENCE CONTROL MODULE

The control system allows for intelligent pump control while improving system reliability. Timers and relays used in a conventional controller are integrated into a single sequence controller. Because all of the timers and relays are software, changes can be made to the system operation without costly re-wiring. The working program is stored on a non-volatile EEPROM chip that is an integral part of the unit. This means there is no danger of ever losing a program due to power losses.

A 7-day military time clock is standard. It is maintained by a super capacitor for a minimum of 8 hours under a power loss condition. See section 2.4 for instructions on how to set the clock.

The following page demonstrates a typical parameter change. The programming of the module is very similar to setting a digital watch. As each unit will contain a program that has been specifically designed for the application, the actual data you will see will vary from that shown in the example.

CHANGING A PARAMETER VALUE

ADJUSTABLE SETTINGS

Parameter Number	Description	Default Setting	Variable Range
B01	Lead Pump Minimum Run Timer	10 m	0-99 m
B02	Lag Pump Minimum Run Timer	10 m	0-99 m
B04	Lead Pump Start Delay Timer	1 s	0-99 s
B05	Lag Pump Start Delay Timer	5 s	0-99 s
B07	Pump Fail to Start Delay Timer	5 s	0-99 s
B12	Low Suction/Temp Pump Shutdown Off-Delay Timer	5 s	0-99 s
B33	Low Suction/Temp Pump Shutdown On-Delay Timer	5 s	0-99 s
B36	Duty Cycle Alternation Enable/Disable Switch When setting item B36 the OFF selection allows the lag pump to stage on during periods of high demand. When B36 is set to ON the lag pump is a standby pump which will turn on in the event the lead pump fails.	OFF	OFF/ON

If any alarms are shown on the display of the programmable pump sequence control unit press the ESC key to proceed with the following instructions.

Pressing the ESC key will cause the unit display to show the following selections:

- STOP – Do not use, this will stop the program
 - SET PARAM – Follow instructions as follows
 - SET CLOCK – Follow instructions as follows
 - PRG NAME – The name of the program loaded in the module, such as: 2 pump with duty
- Use the up and down arrow keys to select SET PARAM and press the OK key to accept your selection.

If you wanted to set the time you would have selected SET CLOCK instead. The time would have been set the same as any other value in the module.

After selecting SET PARAM and pressing the OK key the display will change as shown to the right.

The parameter number is indicated here.

The preset value is indicated here.

A live display of the timer in question is shown here. This can be helpful if you just need to see when a timer is about to expire.

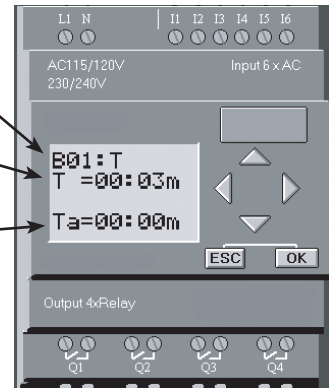

Press the Up and down arrow keys to select the parameter you wish to change.

Press OK to edit the displayed parameter.

Press the left and right arrow keys to select the digit you wish to change. Selected digit will flash.

Press the up and down arrow keys to change the value of the selected digit as required.

Press OK to accept the change. Pressing the ESC key instead of OK will abort and the changes will not be saved.

Use the ESC key to return to the main screen. Each time you press the ESC key you will back up one level from where you are until you finally return to the normal operating screen, which is the date and time display.

CENTRIBOOST **SIMPLEX** TYPICAL FIELD PIPING

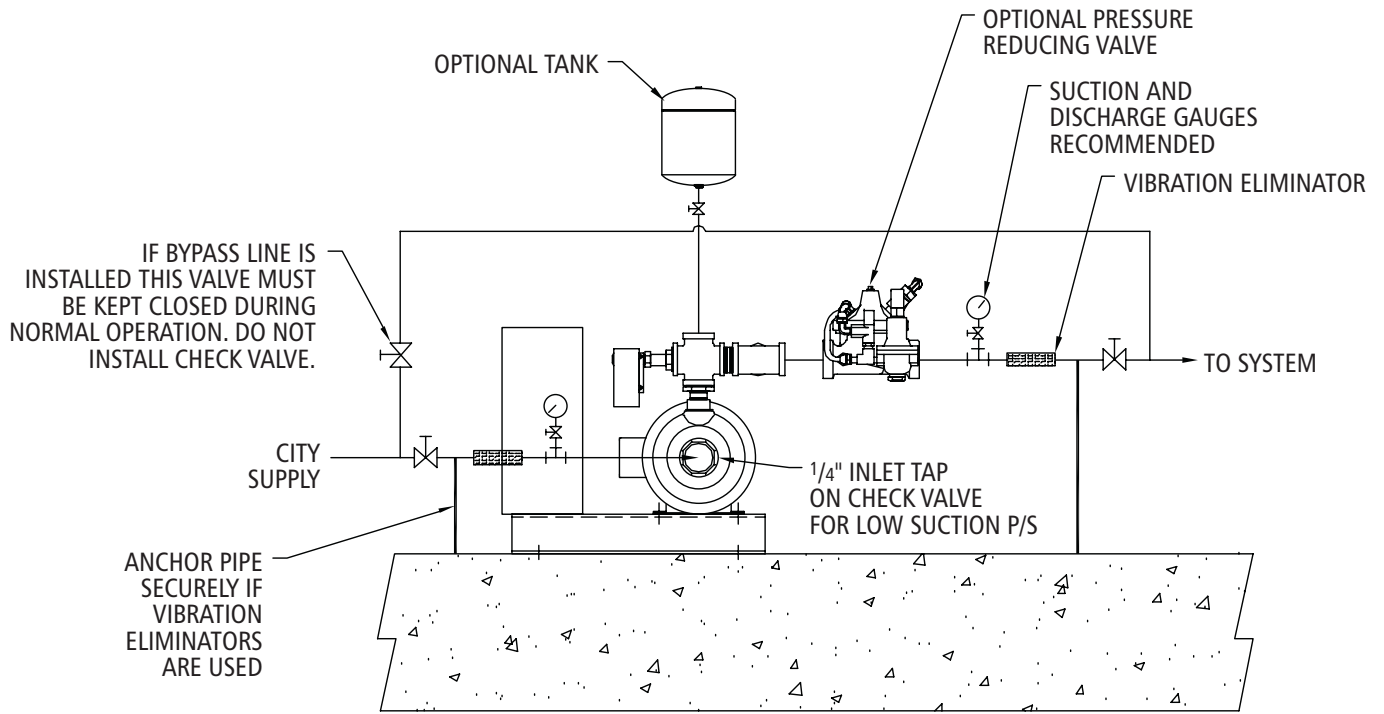

CENTRIBOOST **DUPLEX** TYPICAL FIELD PIPING

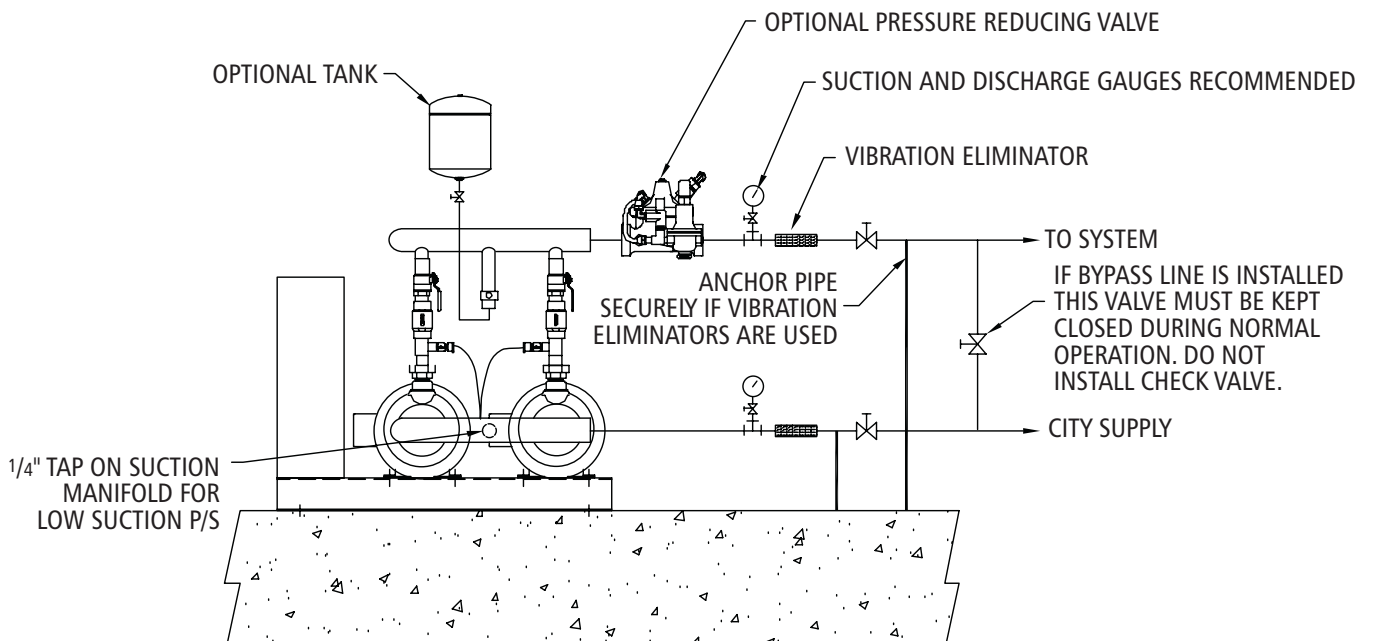

NOTES

NOTES

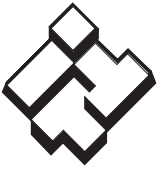

ITT

Commercial Water

GOULDS PUMPS LIMITED WARRANTY

This warranty applies to all water systems pumps manufactured by Goulds Pumps.

Any part or parts found to be defective within the warranty period shall be replaced at no charge to the dealer during the warranty period. The warranty period shall exist for a period of twelve (12) months from date of installation or eighteen (18) months from date of manufacture, whichever period is shorter.

A dealer who believes that a warranty claim exists must contact the authorized Goulds Pumps distributor from whom the pump was purchased and furnish complete details regarding the claim. The distributor is authorized to adjust any warranty claims utilizing the Goulds Pumps Customer Service Department.

The warranty excludes:

- (a) Labor, transportation and related costs incurred by the dealer;
- (b) Reinstallation costs of repaired equipment;
- (c) Reinstallation costs of replacement equipment;
- (d) Consequential damages of any kind; and,
- (e) Reimbursement for loss caused by interruption of service.

For purposes of this warranty, the following terms have these definitions:

- (1) "Distributor" means any individual, partnership, corporation, association, or other legal relationship that stands between Goulds Pumps and the dealer in purchases, consignments or contracts for sale of the subject pumps.
- (2) "Dealer" means any individual, partnership, corporation, association, or other legal relationship which engages in the business of selling or leasing pumps to customers.
- (3) "Customer" means any entity who buys or leases the subject pumps from a dealer. The "customer" may mean an individual, partnership, corporation, limited liability company, association or other legal entity which may engage in any type of business.

THIS WARRANTY EXTENDS TO THE DEALER ONLY.



Goulds Pumps, CentriBoost and the ITT Engineered Blocks Symbol are registered trademarks and tradenames of ITT Corporation.

SPECIFICATIONS ARE SUBJECT TO CHANGE WITHOUT NOTICE.

ITT RESIDENTIAL & COMMERCIAL GROUP, Seneca Falls, NY
(Phone) 315-568-7100 • (Fax) 315-568-7933

IM201R00 March, 2007

© 2007 ITT Corporation

Engineered for life



ISO 9001
Certified